



# EISPC

EASTERN INTERCONNECTION STATES' PLANNING COUNCIL

# Scenario Building from Futures and Sensitivities

**Presentation by Denis Bergeron**

**July 26, 2011 EISPC Meeting**

# Choosing Scenarios

- EISPC and SSC have specified 8 Futures
  - Five relax transmission constraints throughout the Interconnect
  - Two relax constraints only in five “super regions”
  - One does not relax transmission constraints
- Information from the model runs help design three transmission build out scenarios

# Choosing Scenarios

- The futures choices also constrain us a bit
  - The model builds the most economic system it can
  - Relaxed transmission constraints allows it to locate resources in other areas
  - Since transmission moves power from “source” to “sink”, we need to make sure we provide adequate resources to maintain this relationship as we propose transmission scenarios
  - The three scenarios will each look quite a bit like one of the futures already modeled

# Choosing Scenarios

- The policies we model will drive the 3 build out scenarios
  - F1, F4, F7, and F8 do not prohibit coordinated top down planning, but there is nothing to encourage it
  - The Low Carbon and high RPS futures are designed to provide two “book end” transfers
    - F2 and F5 achieve policy objectives by allowing broad national transmission transfers
    - F3 and F6 achieve the objective by limiting increased transfers to within five “super regions” )

# Three Scenarios: A top down view

- One: No Greater Coordination: Data from F1, F4, F7, or F8 NEEM model results (prefer BAU as a reference)
- Two: Super Region Planning: Data gathered from F3, F6 NEEM results
- Three: National or Top Down: Data from F2, F5 NEEM results

# How do we choose?

- A first step is to establish “common denominator” facilities.
  - All three scenarios, use transmission facilities that show up in each relaxed constraint run in all futures.
  - For “super regions” use transmission facilities that show up in output of both F3, F6
  - For “top down” scenario, use those common to both F2, F5

# What do we see so far?

- Only 4 expansions common to all futures
- Only 5 expansions are common to the low carbon and RPS “super region” futures (F3, F6)
- There are 16 transmission expansions common to low carbon and RPS “national” or “top down” futures (F2,F5)

# Relaxed Constraints All Futures

Interface	F1	F2	F3	F5	F6	F7	F8	Sum
MISO WUMS to MISO MI	10,054	688	1,323	49	830	235	4,604	17,783
NE to SPP N	2,911	160	2	10,998	1,201	1,055	1,033	17,360
NYISO AF to NYISO GHI	1,059	1,435	1,593	638	507	742	1,570	7,544
NEISO to NYISO J&K	57	825	347	90	70	203	934	2,526

These 4 interfaces should be part of all three scenarios

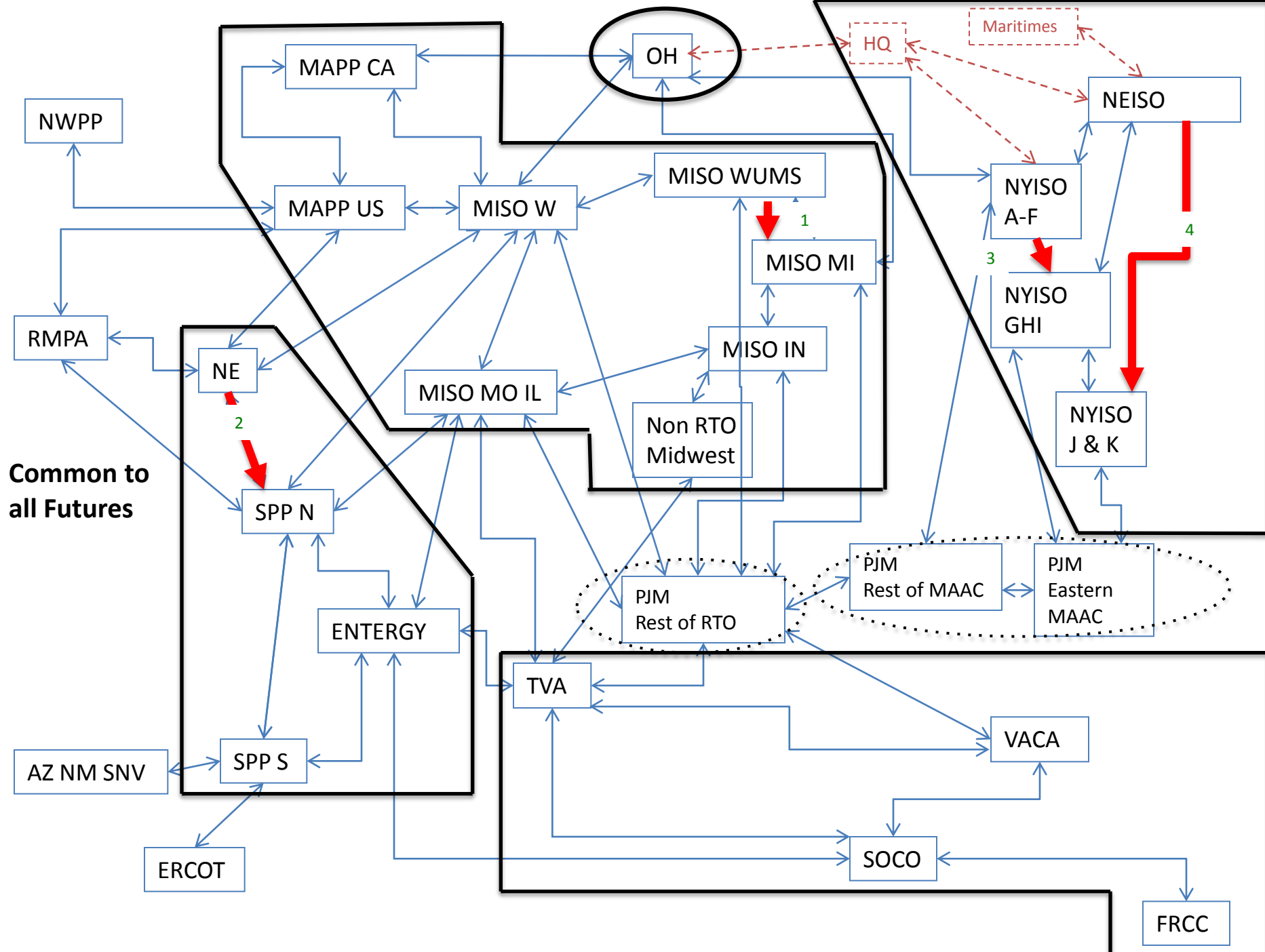

**Common to all Futures**

Maritimes

HQ

OH

NEISO

MAPP CA

NWPP

MAPP US

MISO W

MISO WUMS

MISO MI

MISO IN

MISO MO IL

Non RTO Midwest

NYISO A-F

NYISO GHI

NYISO J & K

NE

SPP N

ENERGY

SPP S

AZ NM SNV

ERCOT

TVA

VACA

SOCO

FRCC

PJM Rest of RTO

PJM Rest of MAAC

PJM Eastern MAAC

1

2

3

4

# Relaxed Constraints – Super Regions

Interface	F3	F6	Sum
MISO WUMS to MISO MI	1,323	830	2,153
NYISO AF to NYISO GI	1,593	507	2,100
NE to SPP N	2	1,201	1,203
NEISO to NYISO JK	347	70	417
MAPP CA to MISO W	226	18	244

These 5 interfaces should be part of any regional scenario

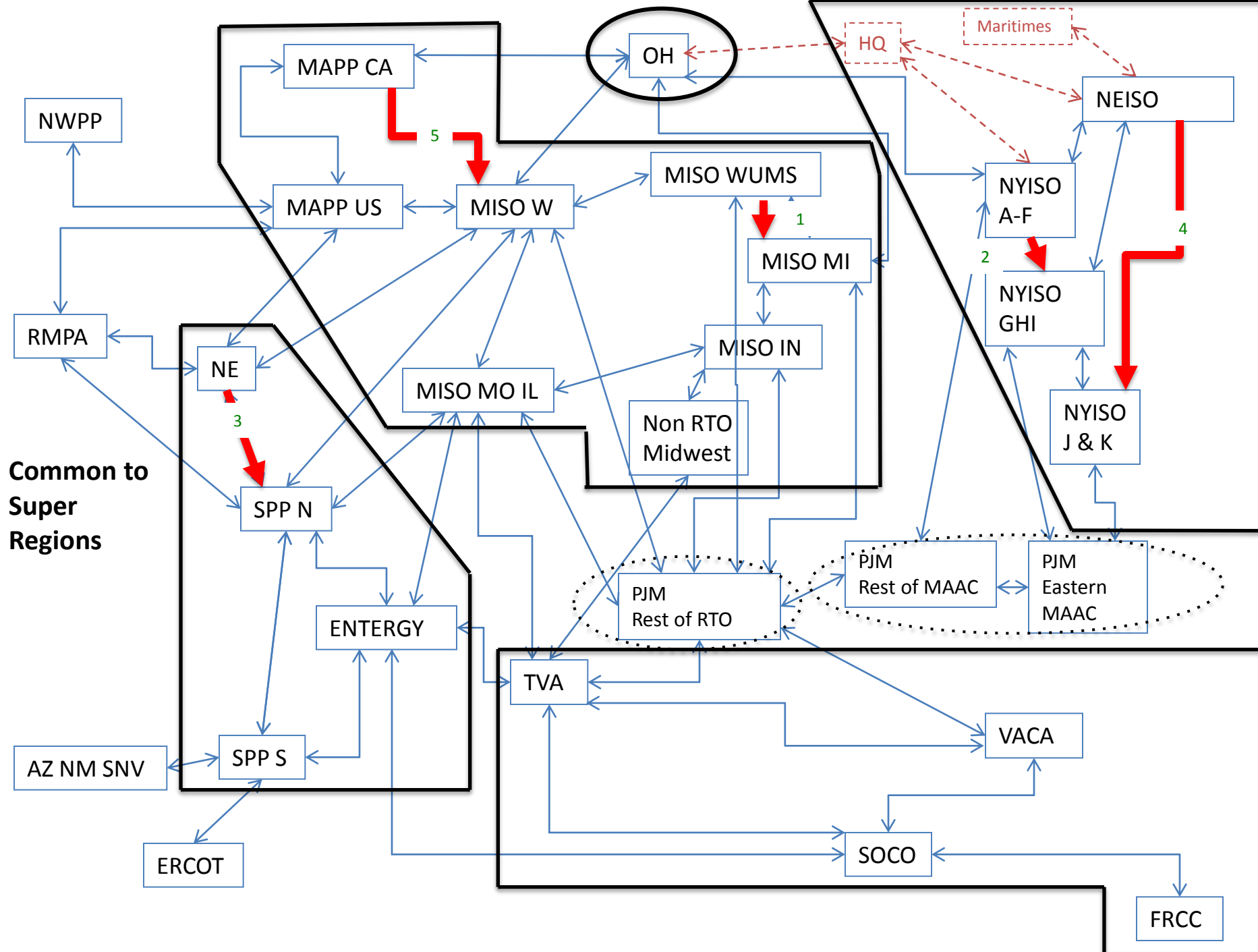

# Relaxed Constraints - National Futures

	Future 2 OL75	Future 5 OL25	SUM
MISO W to PJM ROR	12,420	9,362	21,782
SPPN to Entergy	13,843	7,440	21,283
NE to MISO W	2,489	17,487	19,986
NE to SPPN	160	10,998	11,158
SPPS to Entergy	1,992	4,282	6,274
MISO W to MISO MO IL	122	4,073	4,195
Entergy to SOCO	1,900	431	2,331
SPP N to MISO MO IL	2,019	263	2,282
MISO W to MISO WUMS	38	2,127	2,165
NYISO AF to NYISO GHI	1,435	638	2,073
SPPN to SPPS	236	1,561	1,807
MISO IN to MISO MI	768	81	849
MISO WUMS to MISO MI	688	49	737
NEISO to NYISO JK	315	90	405
NYISO JK to PJM E	74	70	144
IESO to MISO W	67	74	141

These 16 interfaces should be part of any “top down” scenarios

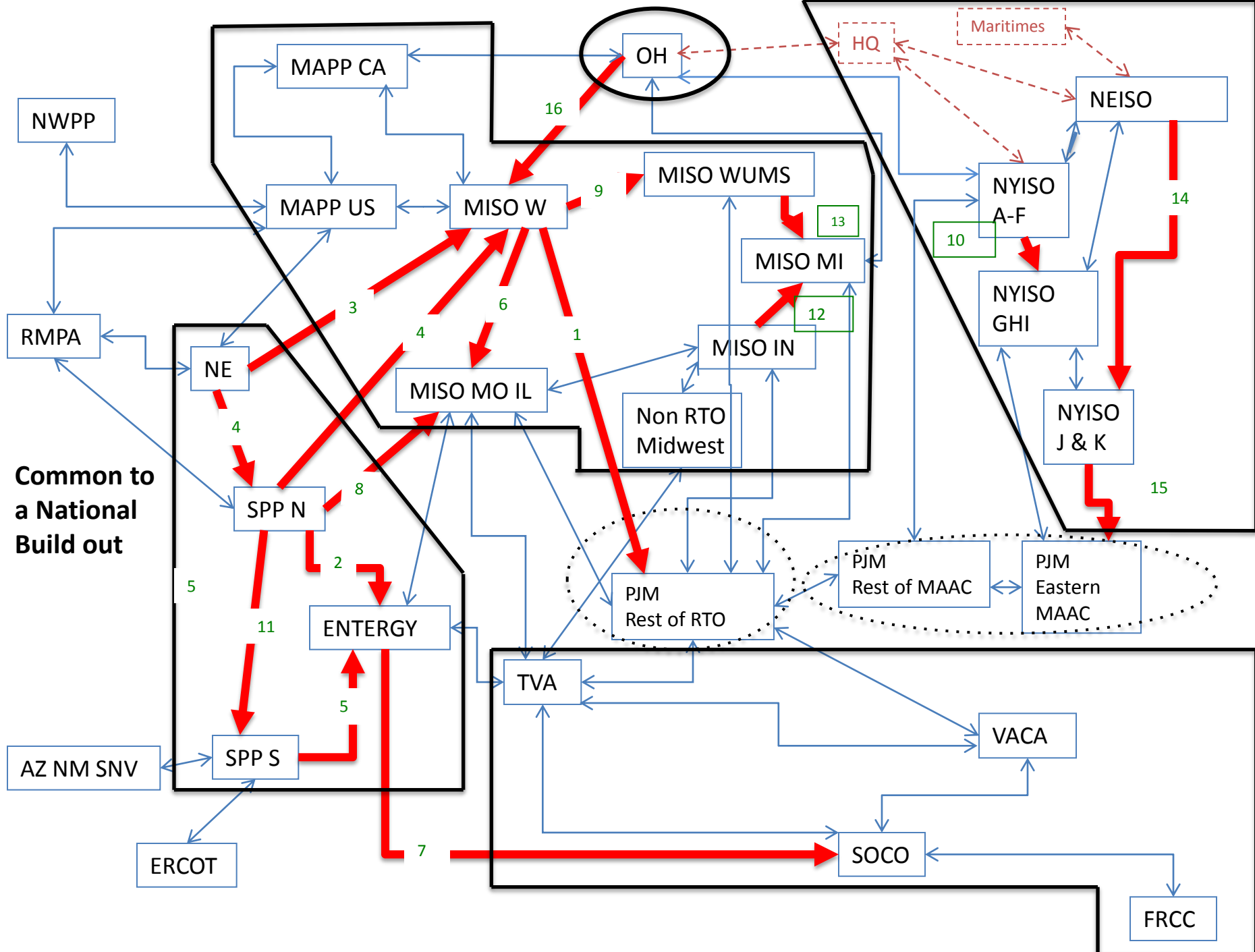

# Still Much to Do

- Common denominator facilities are a small fraction of what different model runs indicate.
- We've got plenty of options to choose from

# Our Charge

The task force has been asked to select a set of scenarios that collectively “push the envelope” and most task force members agree with this concept, in principle. However some task force members are wary of selecting scenarios that result in transmission build-outs that are impossible to achieve. The Task Force has not reached consensus on how to define “plausibility” or “impossibility”.

July 20 Scenario Task Force memo on recommended criteria for scenario selection

# Transmission Expansion Options

Future/Sensitivity	Facilities Affected	Total Transfer
F1S1	12	3,741
F1S2	14	21,876
F2S1	19	39,917
<b>F2S2</b>	<b>25</b>	<b>121,707</b>
F3S1	9	4,263
F5S1	16	16,753
F5S2	20	64,203
<b>F6S2</b>	<b>8</b>	<b>3,082</b>
F7S1	13	4,963
F8S1	18	36,978
F8S2	24	90,758

